

Flight cases / Instruments flight cases / Flight cases for Marimba, xylophone & vibraphone

## Flight case for dismantled Adams XCHV xylophone

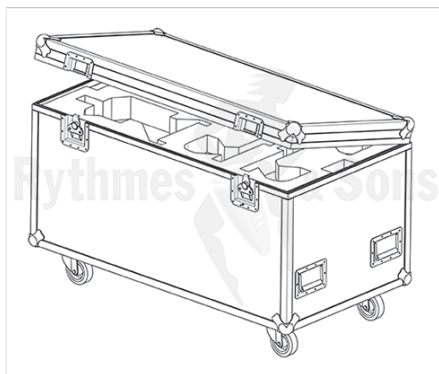

## CARACTÉRISTIQUES TECHNIQUES

Référence produit	FPX ADXCHV DA
Poids brut (kg)	51.00
Music instruments	Xylophone
Packed brand	ADAMS
Model	XCHV
Quantity per case	1
Overall dim. (mm)	1200x640xH740

### FLIGHT CASE FOR DISMANTLED XCHV ADAMS XYLOPHONE

- > "Trunck" shaped
- > Hinged top lid
- > 9 mm BROWN phenolic faced birch plywood
- > 2 large recessed butterfly latches with guided opening/closing mechanism (1 with padlock brackets)
- > 2 lid stays in dish on the back
- > 4 recessed flip handles with double sprung
- > 4 swivel castors Ø100 (2 with brake)

#### Interior features

- > Foam padding